

DE=	EN=	PT=	VN=
Scraping with machine 1/4			

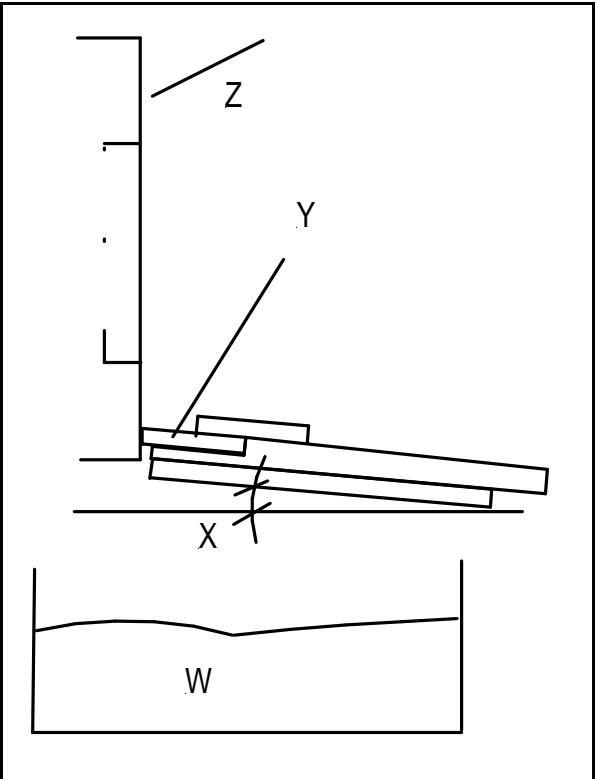
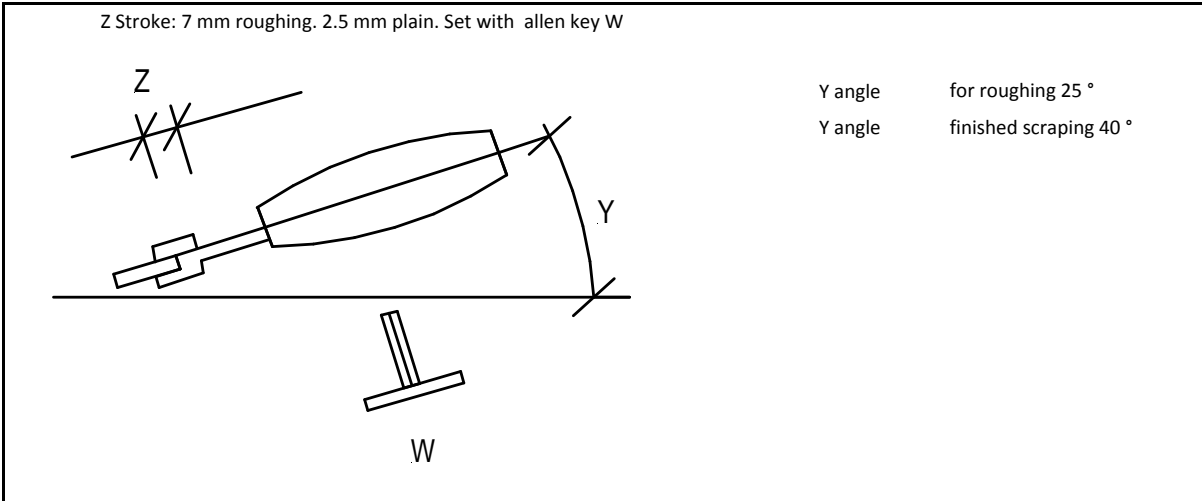

W here means: petroleum as a cooling lubricant

Z is the diamond disc.

The pressing pressure with Y is maximum 20 grams

Y denotes the carbide scraper

X is 5 ° clearance angle grinding

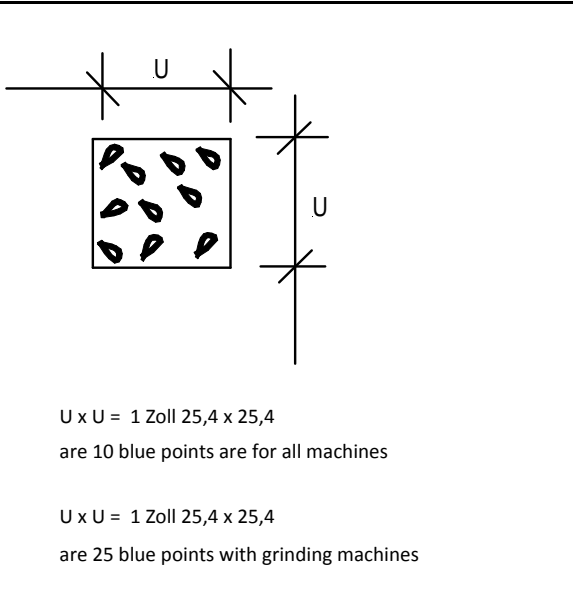
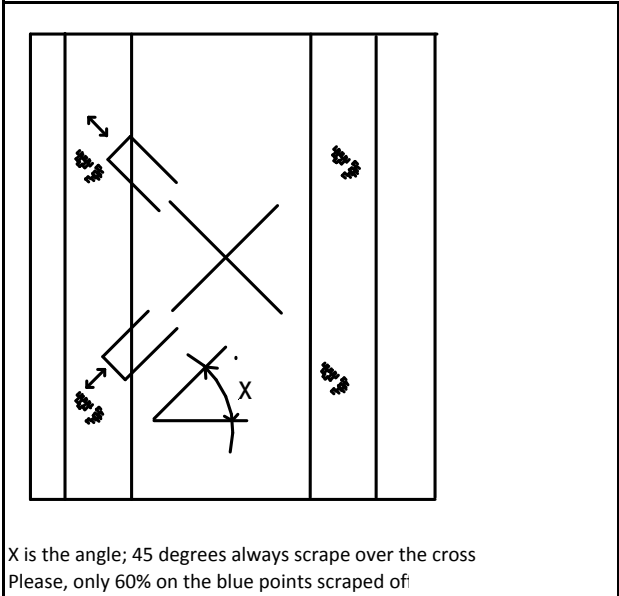

gezeichnet:	hpw	Datum:	18.10.2011	education project	Schaben mit Maschine 01	translate/en_iw/p_ct/vn_r	origin:wiap_kfkok
Aenderung:	an	Datum:	23.06.2015	WIAP KFKOK	Scraping with machine 01	r5	wi_8_f_19_o_a1_r5_Scraping_p1_
Aenderung:	control 2	Data:		Safenwil Schweiz	spear 2	www.wiap.ch	idee of / from: hpw

DE=	EN=	PT=	VN=
Files as a scraper 2/4			

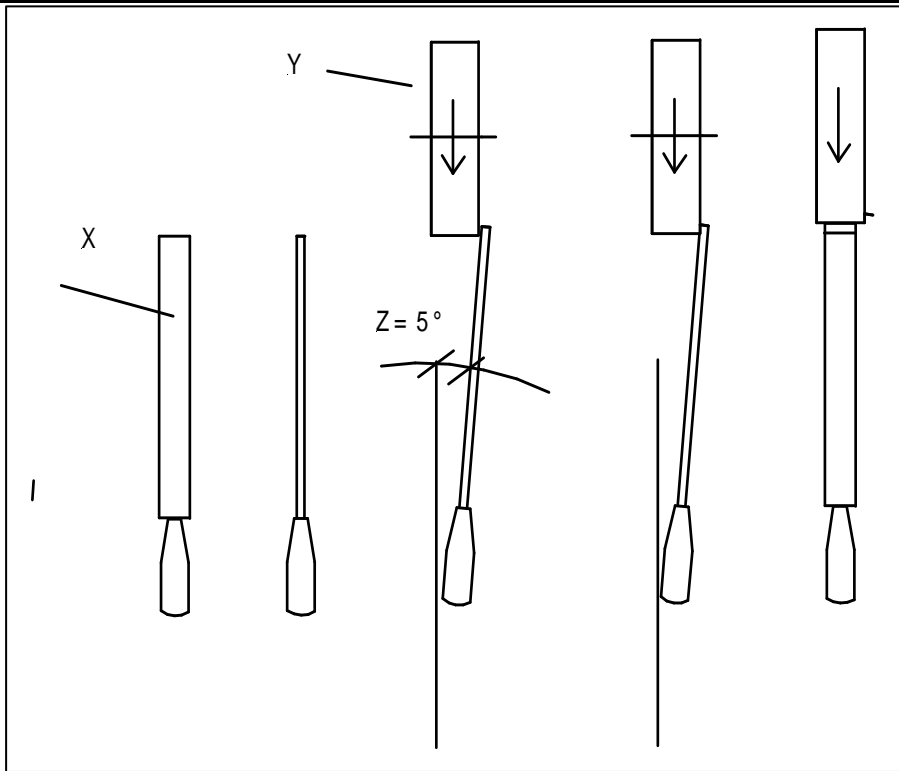

Take a normal flat file (X). Go to the grinding disc (Y).
 Hold the flat file with 5 ° clearance angle to the grinding disc (Y). Grind the clearance angle.
 The file always good cooling with water during the grinding. If the file change the color to blue, it's loses hardness. Therefore, cool wiht water.
 Two sides grind and flat front grind, then you have a good own scraper.



grinder



view file ground

gezeichnet:	hpw	Datum:	18.10.2011	education project	Feilen Schaber	translate/en_iw/p_ct/vn_r	origin:wiap_kfkok
Aenderung:	an	Datum:	23.06.2015	WIAP KFKOK	Files as a scraper	r5	wi_8_f_19_o_a1_r5_Scraping_p1_
Aenderung:	control 2	Data:		Safenwil Schweiz	spear 2	www.wiap.ch	idee of / from: hpw

DE =		EN=		PT=		VN=	
Scraper machine 3/4							
				Scraper machine 10 points each/inch		Stroke length adjustment 0 - 20 mm	
				Sharpening stone cleaner strew with quartz sand		about 0.05 l Petrol give on the sharpening stone	
				Roughing 25 ° 7 mm stroke Finishing 40 ° 2 mm stroke		Adjust stroke with a 6 mm Allen key	
Stroke adjustment up to 1600 minute		Different scraping tools		Dirty sharpening stone		After that, wash stone very good	

gezeichnet:	hpw	Datum:	18.10.2011	education project	Schabmaschine	translate/en_iw/p_ct/vn_r	origin:wiap_kfkok
Aenderung:	an	Datum:	23.06.2015	WIAP KFKOK	scrabmaschine	r5	wi_8_f_19_o_a1_r5_Scraping_p1_
Aenderung:	control 2	Data:		Safenwil Schweiz	spear 2	www.wiap.ch	idee of / from: hpw

DE=	EN=	PT=	VN=
	Scrap equipment 4/4		



Surface plate 800 x 1200 mm



Large ruler 400 mm wide. For 20 meters machine beds



Blueing of the company Brüttsch Rüeegger



Various scraping knife



Surface plate 400 x 600 mm



Different ground shafts, some with cones



Open blueing in a clean box



Diamond scraping knife sharpener
5 degrees free angle



Different straightedge, also for dovetail



Scraped precision angle



Blueing role ever in a clean
Plastic bag to protect against the dirt



Cooling with petroleum. Only 5 grams of
pressing pressure

gezeichnet:	hpw	Datum:	18.10.2011	education project	Schabmaschine 06	translate/en_iw/p_ct/vn_r	origin:wiap_kfkok
Aenderung:	an	Datum:	23.06.2015	WIAP KFKOK	scrabmaschine 06	r5	wi_8_f_19_o_a1_r5_Scraping_p1_
Aenderung:	control 2	Data:		Safenwil Schweiz	spear 2	www.wiap.ch	idee of / from: hpw